



BIOMASS BOILER
ATTACK PELLET 30
AUTOMATIC PLUS



WWW.ATTACK.SK



ABOUT THE COMPANY ATTACK, S.R.O.

- *The largest Slovak producer of heat technology with purely Slovak capital and sole owner.*
- *Company has been operating on the market for 17 years. Within this period, it has managed to us to reach more than 46 countries of the world.*
- *The widest assortment of products for solid fuel, pellets (biomass), natural gas and LPG – propane.*

The main purpose and philosophy of the company ATTACK, s.r.o. is to develop top products of the best quality, functionality and design, achieving the highest combustion efficiency by respecting the environment and keeping the favourable price.

PRODUCT PORTFOLIO

Product portfolio of the ATTACK, s.r.o. company is characterized by wide assortment of the ATTACK® products, classified by concrete product type, output and kind of fuel - natural gas, LPG propane, solid fuel or pellets (biomass).

Recently, there is the widest product portfolio of the ATTACK, s.r.o. company. By every product group there are many options of modifications and outputs.

PRODUCTS:

- *2 lines of wood gasifying boilers ATTACK DP and ATTACK DPX – 32 models*
- *Pellet boilers, pellet burners – 4 models*
- *Indoor pellet stoves (warm-air and warm-water) – 30 models*
- *Cast iron boilers for solid fuel and pellets – 22 models*
- *Accumulation tanks – 74 models*
- *Solar technique – 18 solar sets*
- *Wall hung gas condensing boilers – 6 models*
- *Wall hung gas atmospheric boilers – 6 models*
- *Floor standing cast iron gas boilers – 92 models*
- *D.H.W. tanks (directly and indirectly heated) – 4 models*
- *Wall hung electric boilers – 4 models*
- *Radiators – 855 models*
- *Other accessories and spare parts – 32 models*

AWARDS



The ATTACK, s.r.o. company struggles to make every product to be among the best in its class. Almost all our product groups have achieved plenty of awards at domestic and international exhibitions, given by the committee of specialists.

CERTIFICATES

The ATTACK, s.r.o. company is holder of the quality certificate ISO 9001 for:

- *boiler design and development*
- *boiler manufacturing*
- *service of boiler and appliances*



All the articles are approved and tested for the CE, TÜV, and GOST certificates, granted by prestigious test institutes.

RESEARCH AND DEVELOPMENT

The ATTACK, s.r.o. company has its own research and development center. The company emphasizes development of sophisticated and innovative products of high quality, competitive on the European as well as on the world markets. All the ATTACK® products are designed and developed in conformity with appropriate norms, specifications, juridical and other prescriptions.

Suitable components are selected under the strictest criteria. For assembly of the ATTACK® boilers can be used only reliable and by long-time utilization approved components and materials from prestigious suppliers.

The ATTACK, s.r.o. does not cooperate in development with other producers, but struggles to be a step before the competition.

THE ATTACK PRODUCTION PLANT

Assembly of floor standing and wall hung boilers

The ATTACK, s.r.o. manufactures products in own production halls. Production is divided into production of biomass boilers from cast iron and steel, wall hung gas boilers and floor standing cast iron boilers.

Production of biomass boilers

The ATTACK, s.r.o. disposes with the newest and the most modern technology for boiler production (robotized welding workstations, laser workstation, CNC workstation, bending with active angle measuring, ...), which exceeds actual European standard in many ways and markedly increases quality of final products.

Technology of biomass boiler production

There are the highest requirements for the ATTACK® product quality. Boilers are made from special boiler sheet metal.



WHY TO CHOOSE THE ATTACK, S.R.O. COMPANY?

- *More than 500.000 products manufactured within 17 years of the company operation*
- *The most modern production technologies used to manufacture the ATTACK® products*
- *Innovative solutions*

- *Excellent customer and emission values of the products*
- *Complete technical support*
- *Top products of the best quality, functionality and design*
- *Training organized for customers and partners anywhere in the world*
- *Wide assortment of products for biomass and gas and solar technique from one manufacturer*

EXPORT ACTIVITIES

Export activities of the ATTACK company have been developed in more than 46 countries of the world and this number is still increasing. Nowadays we export our products to all EU countries, Russia, USA, Canada, Australia and New Zealand. Modern wood gasifying and pellet boilers have gained the biggest interest and they are demanded in Europe and in America as well. Our floor standing gas boilers represent us even in the far Siberia.

In different countries there is demand for different products. Personal approach to every customer helps us to fulfil particular requirements and to achieve more and more cus-



tomers in new countries. The ATTACK, s.r.o. company is able to satisfy everyone thanks to the wide product offer.

BOILERS FOR BIOMASS BURNING ATTACK PELLET 30 AUTOMATIC PLUS

Modern wood pellet burning boilers **ATTACK PELLET 30 Automatic Plus** save environment by their perfect combustion. Their user enjoys comfort comparable to gas burning. They are intended for heating of dwelling houses, cottages, small plants, workrooms and similar objects.

BOILER ADVANTAGES

- *Modern compact design*
- *Automatic boiler operation controlled by room regulation ensures comfort of heating*
- *High efficiency of burning – low fuel consumption*
- *High efficient tubular exchanger equipped with spiral turbulators for better heat transfer in exchanger, higher boiler efficiency and exchanger cleaning*
- *Stainless steel burner ATTACK*
- *Automatic exchanger cleaning*
- *Automatic ash removing*
- *Easy operation and simple cleaning*
- *Automatic fuel supply*
- *Long time approved construction of boiler body*
- *Quality boiler steel of 6 mm thickness used for boiler manufacturing*
- *High safety and reliability of operation*
- *Low operation costs*
- *Long life-time*
- *Compact dimensions*
- *Simple constructed reliable pellet burner with automatic operation control (i.e. ignition and burn-out), with function of automatic cleaning and error autodiagnosics*
- *Option of additional heating with electric coil up to the 6 kW output, working also as antifreeze protection*



TECHNICAL PARAMETRES

Parameter	Unit	PELLET 30 Automatic Plus
Nominal output	kW	30
Range of output setting	kW	8 – 30
Heat exchange area	m ²	1,9
Prescribed chimney draught	Pa	15 – 20
Max. operating overpressure of heat. water	kPa	250
Pressure loss of water	Pa	152 ($\Delta T = 10K$), 38 ($\Delta T = 20K$)
Boiler weight	kg	355
Diameter of flue exhaust	mm	150
Boiler height	mm	1 220
Boiler width	mm	575
Boiler depth	mm	1 250
Protection of el. parts	IP	IP 40
Max. el. input (by ignition)	W	600
Operating el. input	W	90
Boiler efficiency	%	90,6
Boiler class by the CO emission (under the EN 303-5)	–	3
Flue gas temperature by nominal output	°C	143
Prescribed fuel	–	wood pellets d = 6 – 10 mm, l = 35 mm max.
Average fuel	kg.h ⁻¹	2,4 – 6,9
Volume of water in boiler	l	62
Range of temperature setting of heat. water	°C	60 – 90
Connection voltage	V / Hz	230 / 50

DIMENSIONS

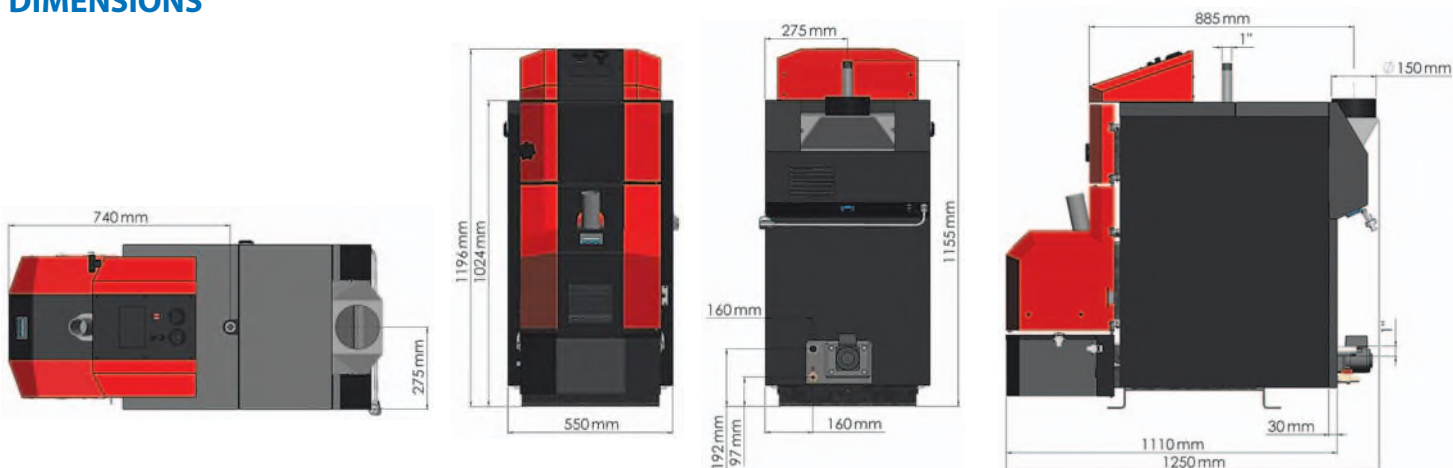



CHARACTERISTIC OF BOILERS ATTACK PELLET 30

Boiler for wood pellets with regulated output of 8–30 kW are intended for heating of dwelling houses and industrial premises. Boiler can be accessorized with **electrical heating device** of 2,4–6 kW output, equipped with own operation and emergency thermostat.

Basic part of the boiler is a water cooled boiler body. Welded piece of the body is made from special boiler steel plates of 4–6 mm thickness, which **guarantees long lifetime** of the boiler. Exchanger is tubular, with turbulators improving heat transfer into the heating water and enabling exchanger cleaning to ensure balanced efficiency.

Fuel is burned in the stainless steel burner, intended for combustion of the wood pellets. **Fuel is automatically ignited by electrical spiral, built into the burner.** Optimal burning conditions and output regulation are provided by **electronically controlled fuel feeding** and air inlet, following the parameters of heating and d.h.w. warming, required and set by the user. Burner, combustion chamber and exchanger are constructed to ensure optimal burning of all combustible materials. Boiler body is isolated with mineral wool, design is completed with powder-treated coating.

The ATTACK Pellet Automatic Plus boiler is equipped with system for **automatic cleaning of tubular boiler exchanger** in intervals adequate to the **automatic ash removing** into detachable box.

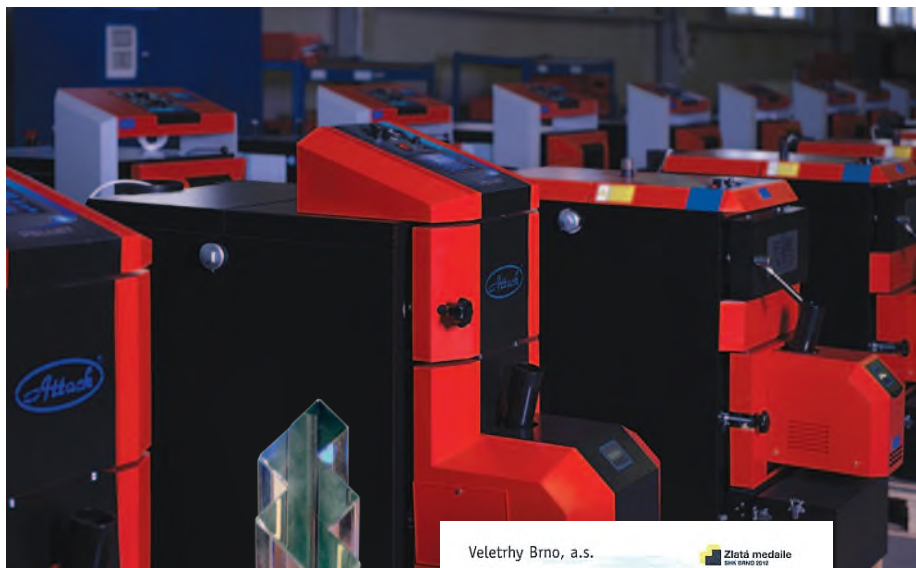

DESCRIPTION

Boiler constructively consists of combustion chamber with partitions and tubular heat exchanger. Beyond the heat exchanger, the flue gas goes into collector with chimney, that can be horizontally or vertically oriented by turning the flange for 180°C. There is a wood pellet burner built-into the boiler body.

The boiler is equipped with spiral fuel feeder (1,5 m), ensuring continual fuel dosing. The **ATTACK PELLETT 30 Automatic Plus** boiler can be delivered with pellet container of 450 l volume (dimesions: 1.024 x 705 x 830 mm).

The „big-bag“ – the external textile tank can be used as an alternative.

By wood pellets combustion in the ATTACK® boiler, there is minimal ash production. Amount of ash depends on quality of pellets and represents approximately 1 % of the consumed fuel.

The **ATTACK PELLETT Automatic Plus** boiler is equipped with automatic system for ash removing into detachable box. Box of appropriate volume has to be emptied one time pro heating season, according to the season and intensity of boiler operation. Boiler can be also accessorized with electrical heating device of **2,4 – 6 kW** output.

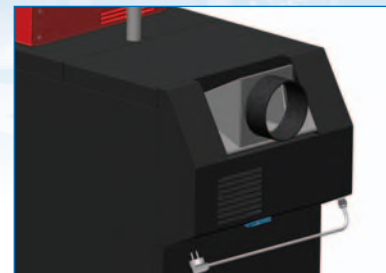

BOILER CONTROL

The **ATTACK PELLETT 30 Automatic Plus** boiler is regulated by the control panel on the upper covering.



1. Main switch of boiler – turns the boiler on / off
2. Burner switch – switches the burner between stand – by and operating modes
3. Boiler thermostat – setting of boiler operating temperature
4. Thermomanometer
5. Reset button – under the cover
6. Fuse 10 A / 250 V
7. Assembly for installation of the REGUMAX regulator

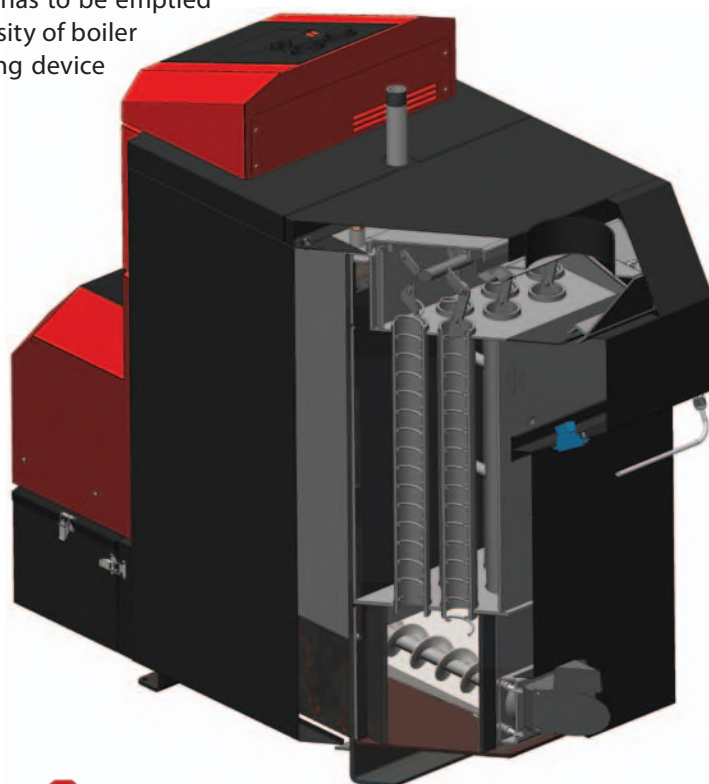

FUEL

Recommended fuel for the **ATTACK PELLETT 30 Automatic Plus** are wood pellets with max. humidity of **12 %**, diameter of **6–10 mm** and max. length of **35 mm**.

Recommended ash content is **1 %**.

Heat value of the prescribed fuel should be **15–17,5 MJ / kg**.



DESCRIPTION OF THE ATTACK PELLET 30 AUTOMATIC BURNER

The **ATTACK stainless steel burner** is based on principle of fuel (pellet) falling – from feeder through supply hose and tube on the grate, where it is burned.

Burner works under fully automatic mode, from evaluation of heat supply need, fuel supply, electrical ignition, burning-up, burning, shutting-down, burning-out, cleaning and switching to the stand-by mode.

Range of the burner's output is: 8–30 kW. Output can be set it in the intervals of 2 kW.

Burner's output range of 14–30kW is set by production and divided into three levels: 1. (14 kW), 2. (22 kW) and 3. (30 kW).

Output range can be changed via the advanced menu in three levels: 8–14 kW, 14–22 kW and 22–30 kW.

Burner is cleaned automatically – after every burning out or in particular time intervals, set by the user, the grate is cleaned by automatic movement towards the scraper. Dirts like ash and eschars fall out of the opening of the grate.

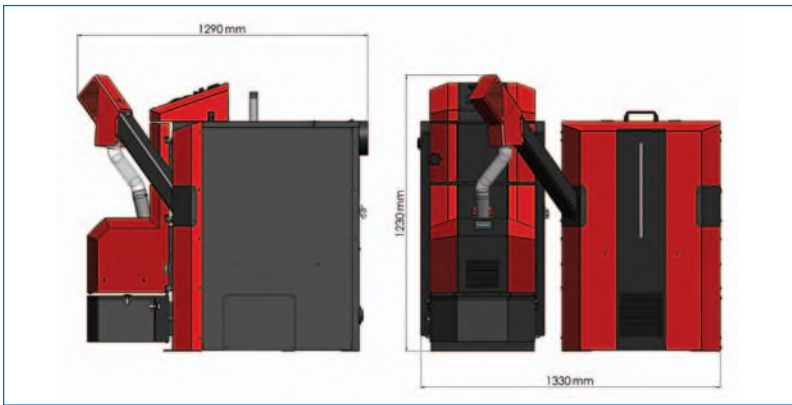
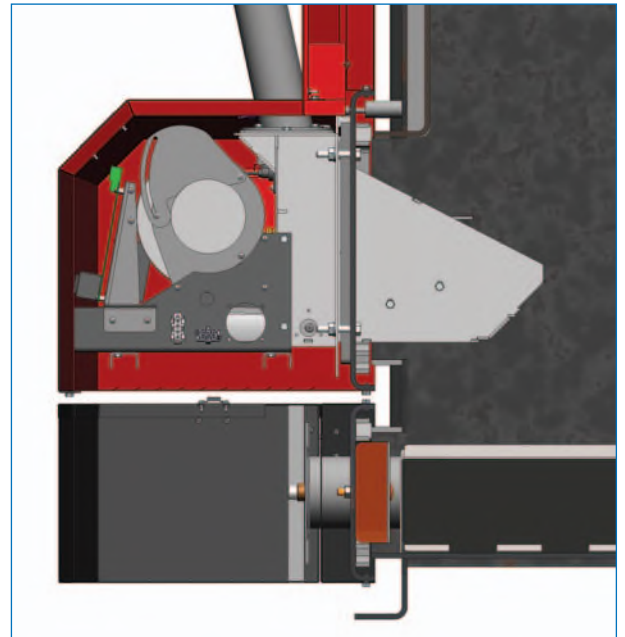
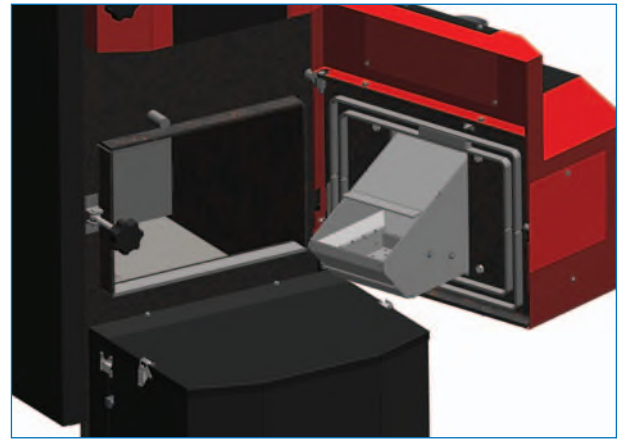

EXAMPLE OF CONNECTION OF THE ATTACK PELLET 30 AUTOMATIC PLUS BOILER

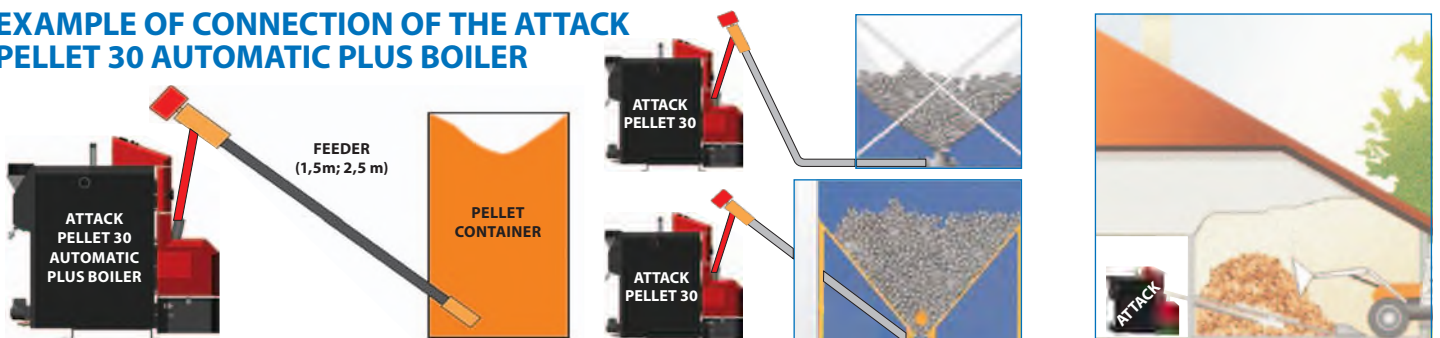

EXAMPLE OF INSTALLATION



Required dimension of the boiler room with the boiler **ATTACK PELLET 30 Automatic Plus** connected to the **450 l pellet tank** and the accumulation tank **ATTACK AS**.

DESCRIPTION OF ATTACK PELLET 30 BOILER

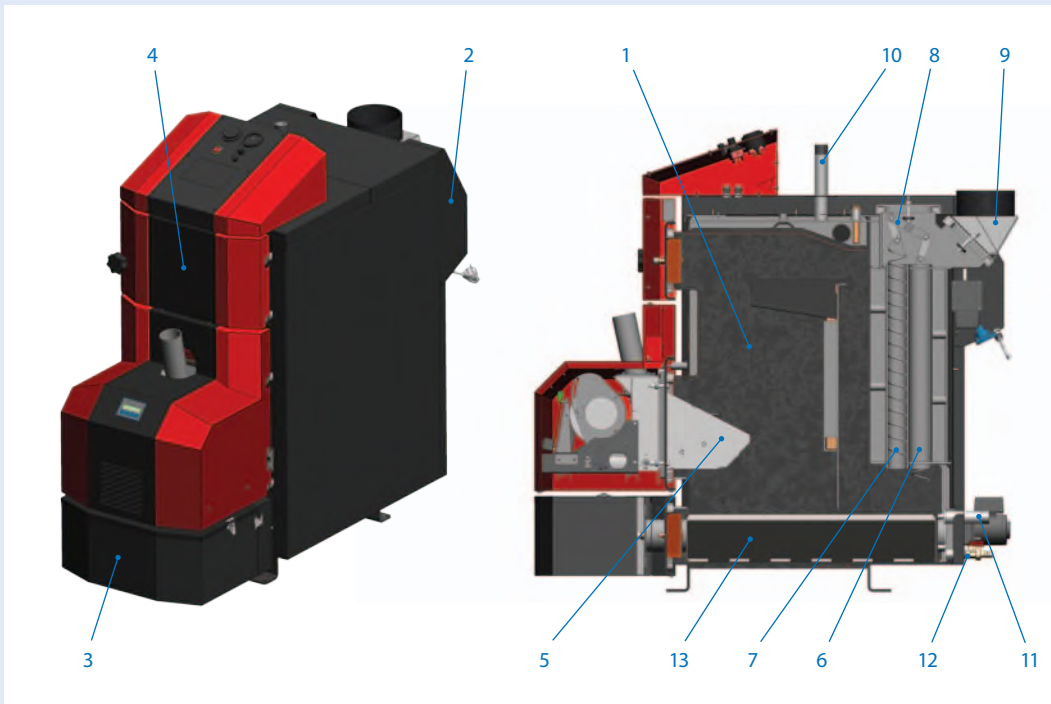

KEY:

- 1. Boiler body
- 2. Covering
- 3. Box for ash
- 4. Door of the inspection opening
- 5. Burner
- 6. Tubular exchanger
- 7. Turbulators
- 8. Pull rod of turbulators
- 9. Flue gas exhaust
- 10. Flow connection 1"
- 11. Return connection 1"
- 12. Drawing valve 1/2"
- 13. Ash tray



THE WAY TO PROTECT AND PROLONG THE BOILER'S LIFE

REGUMAT ATTACK-OVENTROP

When the temperature of return water flowing into the boiler is **low (under 50°C)**, it comes to production of harmful acids, condensate and tar on the steel walls of boiler, and thereby to their damage. **Suitable protective solution to eliminate this harmful effect and to extend life of the boiler is to use the mixing device – Regumat ATTACK-OVENTROP.** By installation of device, the boiler and the heating circuit are created. The mixing device Regumat ATTACK-OVENTROP keeps constant temperature of the return heating water flowing into the boiler **over 65°C**, when the thermostatic head is set on the level 5–6 and prevents damage of the steel walls. The mixing device **ATTACK-OVENTROP** guarantees significantly longer life of the boiler.

Regumat consists of three-way mixing valve, thermostatic head with capilar, by-pass, valve for self-force circulation (alt. natural circulation), three-grade circulating pump, closing valves, thermometers and isolation. **This solution is advantageous, because it is compact, enables simple operation and ensures protection of the steel boiler's heat exchanger.**

Regumat ATTACK-OVENTROP for boiler:

ATTACK DP,DPX 15,25,35, ATTACK PELLET 30 – **DN25**

ATTACK DP,DPX 45–95 – **DN32**

Regumat ATTACK – OVENTROP		
Calibre	DN25	DN32
Max. pressure	10 bar	10bar
Max. temperature	120°C	120°C
Value of KVS	3,9	5,3
Construction height of isolation	365 mm	472 mm
Width of isolation	250 mm	250 mm
Axial distance	125 mm	125 mm

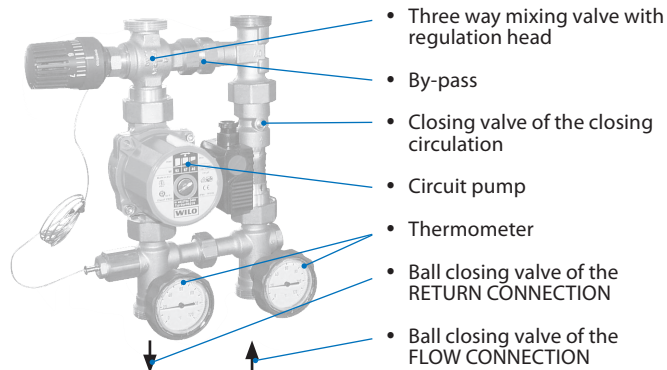
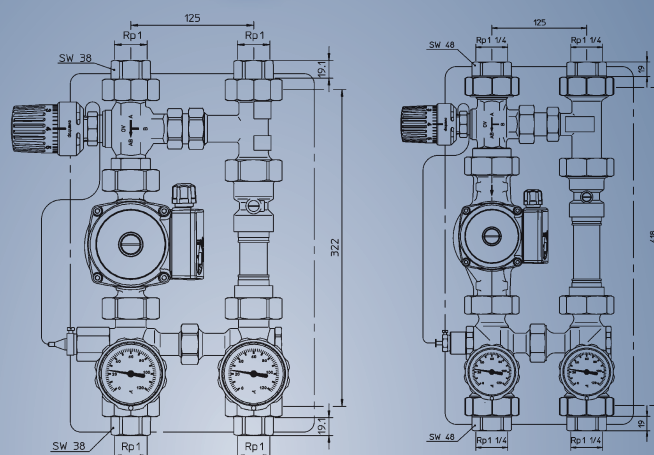

ACCESSORIES FOR THE ATTACK PELLET BOILERS

ACCUMULATION TANK ATTACK

The ATTACK, s.r.o. company is the largest manufacturer of accumulation tanks in Slovak republic with the widest product offer:

ATTACK AK, AS

The accumulation tanks **ATTACK AK, AS** are made from high quality steel. They are intended for accumulation and following distribution of heat energy from biomass boiler (e.g.



ATTACK DP, DPX, PELLET 30, DUAL FUEL, etc.). The ATTACK AS model is accessorized with internal steel coil for connection into solar system.

ATTACK AK: 9x socket G 1 1/2", 4x socket G 1/2"

ATTACK AS: 9x socket G 1 1/2", 4x socket G 1/2", 2x socket G 1" – solar circuit

ATTACK HR, HRS

The **ATTACK HR, HRS** combined tanks are made from quality steel and they serve for heating water storing as well as for hot drinking water production. They are equipped with internal enamel tank. The **ATTACK HRS** model is accessorized with internal steel coil for connection to the solar system.

ATTACK HR: 10x socket G 1 1/2", 6x socket G 1/2", 2x socket G 1" – D.H.W.

ATTACK HRS: 10x socket G 1 1/2", 6x socket G 1/2", 2x socket G 1" – solar circuit, 2x socket G 1" – D.H.W.

ATTACK TUV, TUVS

The **ATTACK®** accumulation tanks **TUV, TUVS** are made from quality steel. They serve for accumulation of heating water and D.H.W. preparation in a copper coil.

The **ATTACK TUVS** model is equipped with an internal steel coil for connection into solar system.

ATTACK TUV: 8x socket G 1 1/2", 5x socket G 1/2", 2x socket G 1" – D.H.W.

ATTACK TUVS: 8x socket G 1 1/2", 5x socket G 1/2", 2x socket G 1" – solar circuit, 2x socket G 1" – D.H.W.

ATTACK S, SS – STRATIFIED COMULATION TANK

ATTACK S – is based on the principle of the **ATTACK AK** tank. Disk and stratification tube installed inside the tank enable creation of layers of water, in dependence on temperature. This construction makes different temperature layers at the inlets as well as at the outlets.

ATTACK SS – is based on the principle of the **ATTACK AS** and **ATTACK S** tanks. Furthermore, it is equipped with one exchanger for connection into solar exchangers.

ADVANTAGES OF INSTALLATION WITH ACCUMULATION TANKS:

- *balanced boiler output*
- *lower fuel consumption – boiler works at full output, with optimal efficiency*
- *longer life of boiler and chimney – by operation at full out-*



- *put there is minimal creation of tars and acids*
- *option to combine with other ways of heating (accumulation electricity, solar devices)*
- *option to combine radiators with floor heating*
- *higher comfort of operation*

See the website www.attack.sk for technical data about another types of tanks.

THE ATTACK REGUMAX EQUITHERMAL REGULATOR

The **ATTACK REGUMAX** equithermal regulator is the top regulation unit for the **ATTACK DP / DPX / PELLET 30** boilers. This controller is intended for regulation of heating systems, including D.H.W. preparation. It is used for control of low-temperature and warm-water systems. Two types of room units (i.e. with and without display) can be connected to this regulation unit.

The equithermal regulator **ATTACK REGUMAX** represents advantage of easy installation with many ways of utilization.

The following aspects of the heating system can be controlled by the **ATTACK REGUMAX**:

- *primary boiler circuit of the wood gasifying boiler*
- *recharging and discharging of accumulation storage devices*
- *solar system for D.H.W. preparation or additional warming of C.H.*
- *several heating circuits of different temperature levels*
- *alternative source of heat*
- *D.H.W. preparation*
- *free programmable inputs*



OPERATION MODES

Heating with and without time program, attenuation mode, summer operation, manual mode, mode of automatic control.

CLOCK FUNCTION

Heating with own week time program, D.H.W. preparation with time week program, 15 holiday periods.

TECHNICAL DATA

Power supply	230 V +6% / -10%
Frequency	50...60 Hz
Output	max. 5,8 VA
Recommended fuse	max. 6,3 VA slow
Grade of protection	IP30
Dimensions (including panel)	144 x 96 x 75 (W x H x D)

EASY INSTALLATION

Easy and quick installation is ensured by connection terminal, connection module or by connection module with spring terminal for installation on the wall.

CONTROL PANEL

Multifunctional display with illumination and clearly displayed data

Setting buttons
• Manual control

• Selection for all heating programs

• Adjustment of heating curves

• Information – overview of temperatures and operation states



Multifunctional button for easy setting by turning and pressing Buttons for quick access

• Required daily temperature

• Required attenuation temperature

• Required temperature of D.H.W.

ADVANTAGES OF THE ATTACK REGUMAX

- Wide possibilities of usage, economical advantage
- Pre-set basic programs for easier projecting and putting into operation
- Multilingual menu – CZ, DE, GB, FR, IT, NL, ES, PT, HU, PL, RO, RU, TR, S, N
- Intuitive control by buttons with symbols, easy multifunctional button, big size text display
- Simple system extension into the small network – possibility to connect several regulators into the communication network
- External modem enables remote switching of modes of the regulator
- Sophisticated control of the heating system, enabling higher comfort of operation
- Equithermal control of temperature of heating water
- High universality for different design varieties of heating systems using wood gasifying boiler

EXAMPLE OF CONNECTION OF THE ATTACK REGUMAX REGULATOR

Universal connection of the REGUMAX regulator with external D.H.W. tank, two mixing valves, solar panels and heat source for solid fuel.

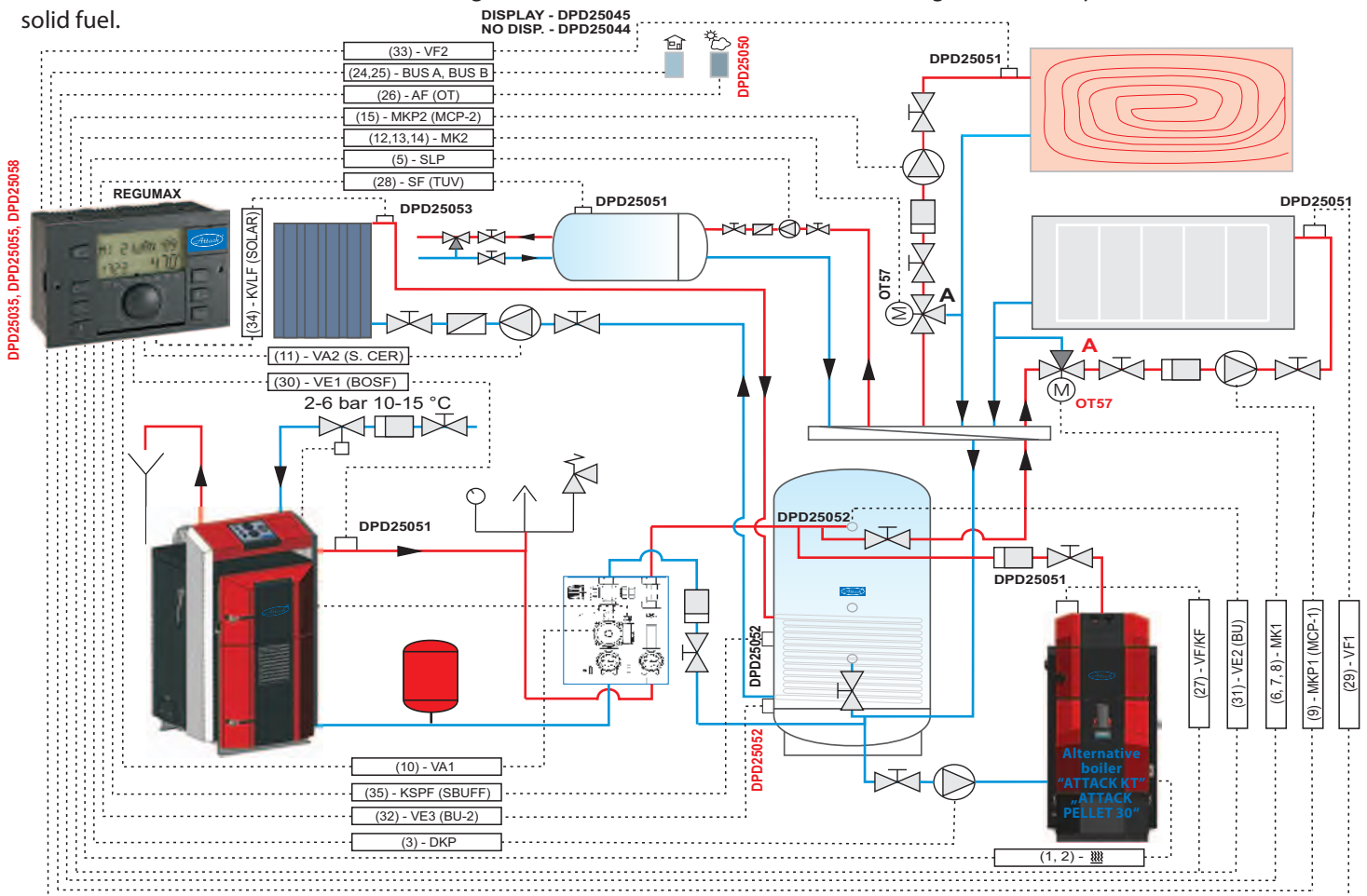



ATTACK, s.r.o.
Dielenská Kružná 5020
038 61 Vrútky
SLOVAKIA

Tel: +421 43 4003 103
Fax: +421 43 4003 116
E-mail: export@attack.sk
Web: www.attack.sk



Výrobca ATTACK s.r.o. si vyhradzuje právo technických zmien výrobkov bez predchádzajúceho upozornenia. • ATTACK, s.r.o. producer reserves the right to change technical parameters and dimensions of boilers without previous warning. • Der Hersteller ATTACK, s.r.o. behält sich das Recht der technischen Veränderungen an Produkten ohne eine vorige Warnung. • Изготовитель ATTACK оставляет за собой право изменения технических параметров и размеров котла без предыдущего предупреждения. • Le producteur ATTACK Sàrl. réserve le droit des modifications techniques sans l'avertissement précédent. • Productor ATTACK, s.r.o. reserva el derecho de cambios técnicos sin advertencia anterior.



ATTACK, s.r.o. – 03/2013